



Gunnebo OptiStile 1080

Modular Turnstile with Swinging Glass Barrier

GUNNEBO[®]

Technical Specifications

Standard Dimensions	Casework Length	48.0"	Walkway Width	28.0" std / 36.0" (ada)
	Casework Height	37.8"	Casework Width	8.8" end unit / 11.2" center unit
	Glass Barrier Height	33.8" / 47.2" / 59.1" / 70.9"		
Orientation, Drive	Bi-Directional, Motorized			
Materials	Pedestal*	#4 grade stainless steel and 0.4" thick tempered glass center		
	Pedestal Lid*	#4 grade stainless steel		
	Barrier	0.4" thick tempered glass		
Drive Mechanism	<p>The moving panels are directly mounted to the output shaft of a DC electric motor and gearbox. The motor and gearbox assembly is mounted vertically in the central column. The moving panel position is monitored by a rotary encoder and the location, speed, and movement are controlled by microprocessor control system. The opening and closing speeds, home, and end positions are adjustable within the controller. Safety photocells prevent the panels from closing on an obstruction. Should the normal panel operation encounter an obstruction, the controlling logic detects an abnormal condition and stops the panels from moving.</p>			
Function	<p>Passage in both directions is electronically controlled. Default mode is Normally Closed (NC), and lane will open only upon acceptance of an authorized signal.</p>			
Flow Rates	Up to 60 users per minute (approximate figures).			
Operation	<p>On receiving a signal from the access control system or pushbutton, the panels open. If an unauthorized person tries to tailgate or enter from the opposite direction, the system detects the unauthorized passage and activates the built-in alarm system.</p>			
Fire Alarm	Input facility, for voltage-free contact supplied by others to effect fail state.			
Power Supply	115VAC 60HZ (230VAC 50HZ available)			
Power Rating	Stand By 20VA; In Operation 120VA			
Logic Voltage	24VAC			
Power Loss	In a loss of power the barrier glass will be completely de-energized and move freely with very minimal force to the open position.			
Certification	UL 2593; Outline for motor-driven turnstile operators and systems.			

*As standard. See Accessories and Options for alternatives.

Operational Modes & Notifications

Interface

Potential free contact provided by either card reader or pushbutton input. Card reader inhibit and reset signals are available as standard. The unit has an adjustable time out facility if required; the go ahead symbol will be cancelled if the passage through the lane is not completed within a pre-set and field programmable time frame.

Operational Modes

Full-Time Barrier (Normally Closed Mode)

The swinging panels remain closed until a valid access control card is presented. Tailgaters and unauthorized entries are signaled by an alarm-type tone. If an unauthorized card is presented, the lane will sound an alarm and the panels will remain closed to prevent the user from proceeding further without intervention.

Standard Operating Modes

Switchable via optional pushbutton (DTC) or touchscreen (MP Touch) controller.

Enter/Card In	Reset
Exit/Card Out	Close
Free Exit/Card Out	

Pictogram Lights

LED display pictograms visually assist the user when passing through the unit. Included as standard.

Accessories & Options

Alternative Materials and Finishes Wide range of custom materials and finishes (including brass, bronze, oxidized stainless steel, and powder coat paint) to suit any architectural design.

Card Reader Options Custom integration of customer-supplied readers into pedestal lid. Proximity, magnetic stripe, biometric, and barcode readers all compatible.

Remote Lane Control Remote lane control via personal computer, tablet, or smartphone. Optional desktop pushbutton (DTC) or touchscreen (MP Touch) controller with advanced controls.

Alternative Mounting Specialized mounting base platforms giving concealed cableway and requiring no drilling, trenching, or core drilling to the floor.

Static Panels When extra space presents in a design, integrated or standalone barrier solutions can be provided.

Elevator Destination Dispatch Mounting integration of customer-supplied LCD screens for elevator destination dispatch systems.



Standard Dimensions

Gunnebo OptiStile 1080

For installation details, please refer to the installation manual.

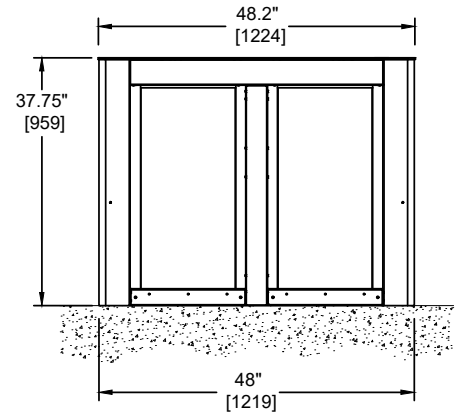
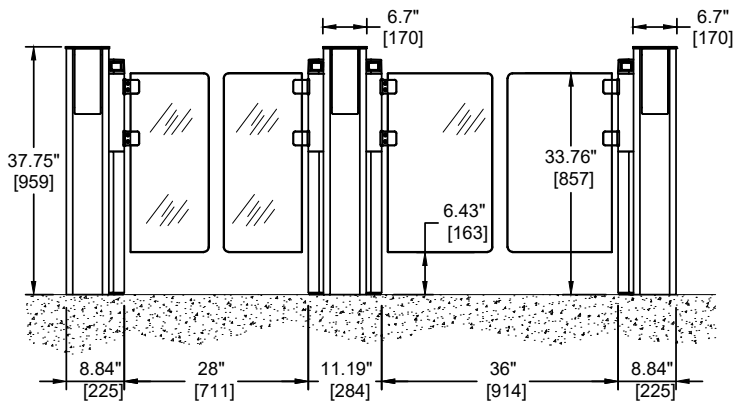
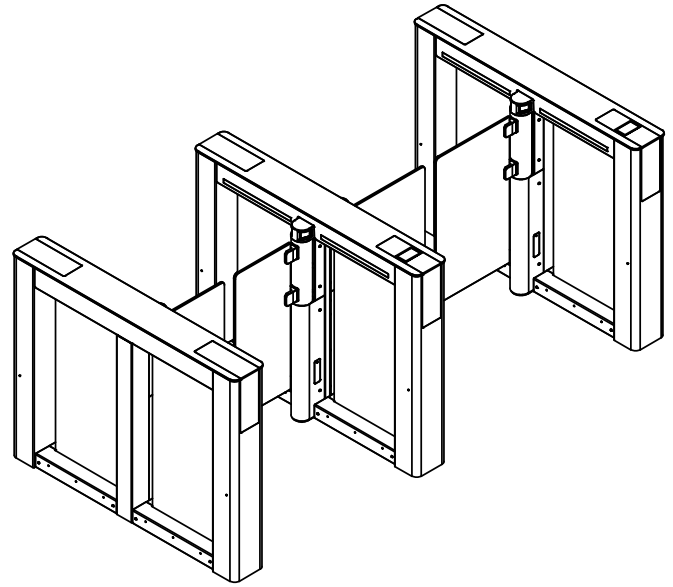
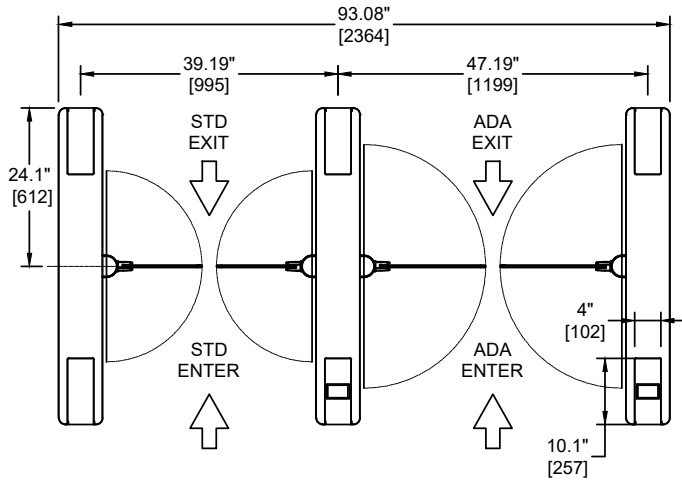

For further information, please contact:

Gunnebo Entrance Control Inc.

535 Getty Ct., Benicia, CA 94510

www.gunneboentrancesecurity.com

