

8

7

6

5

4

3

2

1

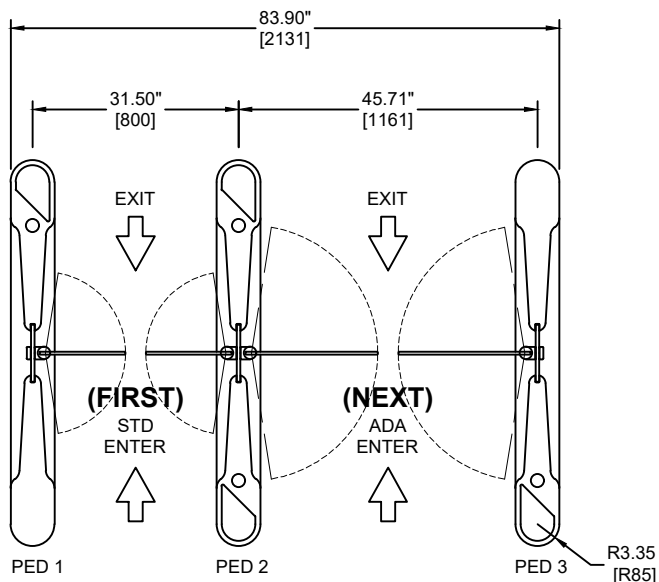

**PLAN VIEW**

# 2L3P SPEEDSTILE FL 1500

## CARD IN / CARD OUT

### DETAILS:

- #4 Brushed 304 Stainless Steel
- Black Anodized Tops / Lids
- Standard Grey Inlays
- Top Flush-Mounted LED Pictogram Grant Entry Indicator
- Battery Backup on Power Failure
- Light Curtain Safety in Lane
- Waymode Indicator on End Legs (Entry & Exit)

UNIT POSITIONING:  
Please allow 50 mm minimum clearance to the rear of the FL – to enable removal of the Access panels.

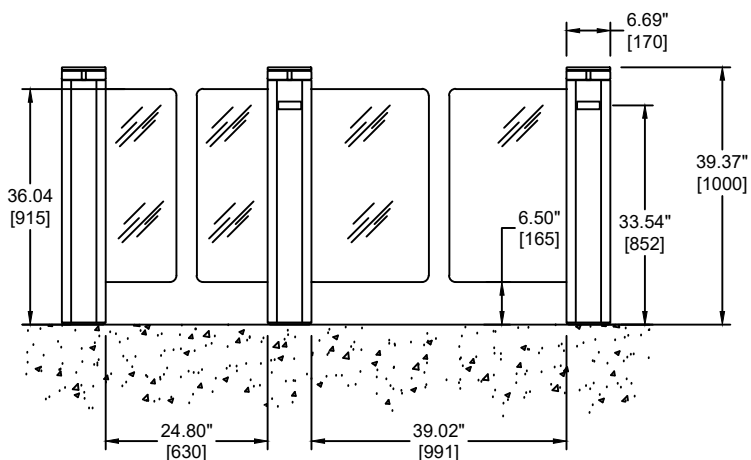

**ELEVATION VIEW**

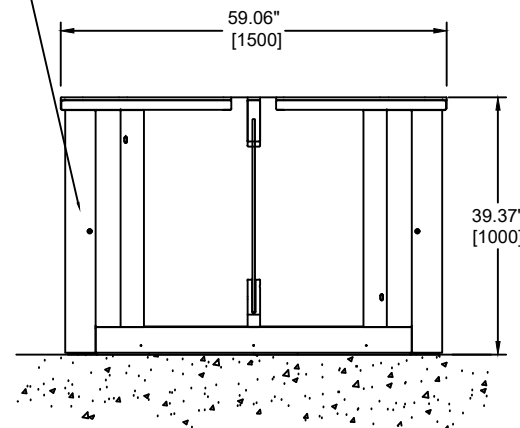

**SIDE VIEW**



|                              |              |                      |
|------------------------------|--------------|----------------------|
| Job Name:                    |              | Date: 07/26/18       |
| Job No: PROPOSAL             | Drawn By: EC | Scale: NTS           |
| Title: 2L / 3P SPEEDSTILE FL |              | Dwg No. SHT-1 (REV-) |

8

7

6

5

4

3

2

1

# FL 1500 - MOUNTING TEMPLATE

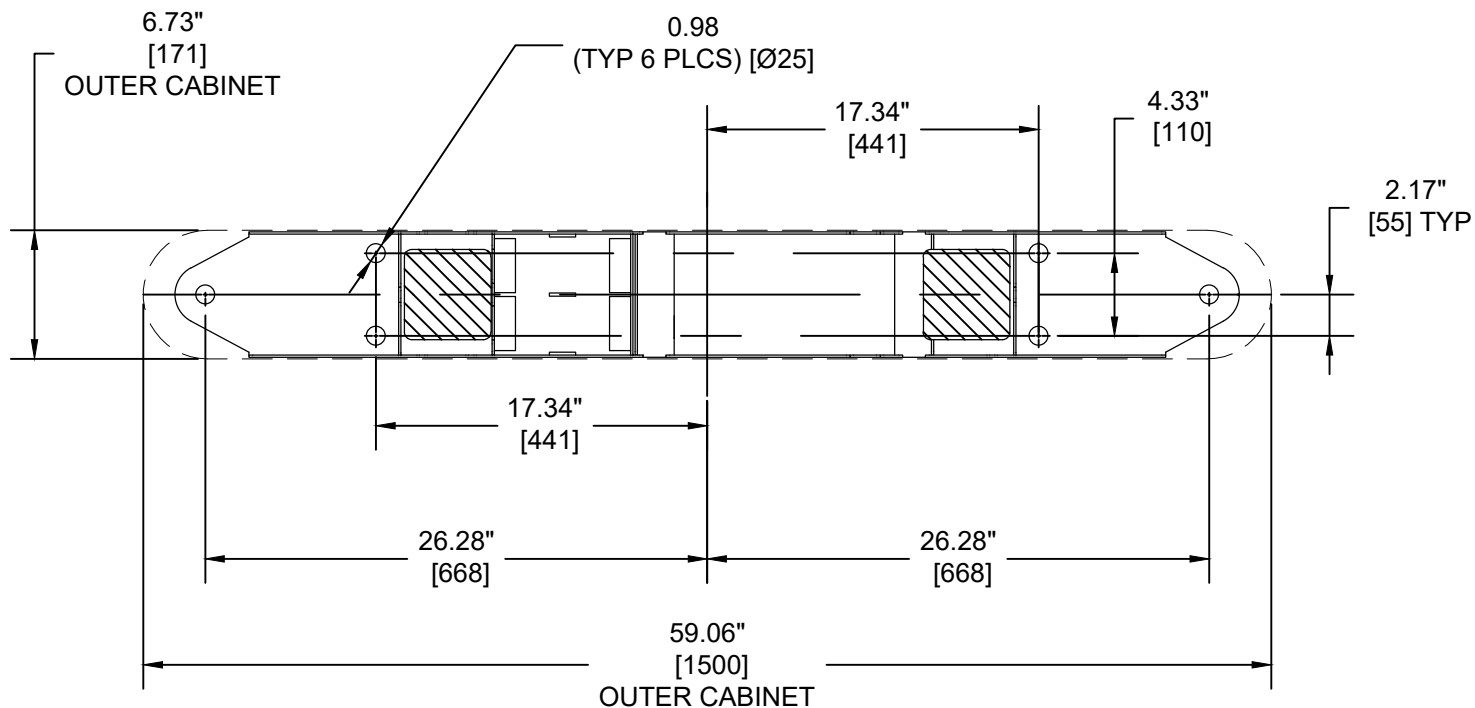

|   |              |                      |
|---|--------------|----------------------|
| Job Name:                                     |              | Date: 07/26/18       |
| Job No: PROPOSAL                              | Drawn By: EC | Scale: NTS           |
| Title: SPEEDSTILE FL 1500 - MOUNTING TEMPLATE |              | Dwg No. SHT-2 (REV-) |