



SpeedStile FL

Speed Gate with Swinging Glass Barrier



Gunnebo's SpeedStile FL brings together slim design, versatility, efficiency, and uncompromised security. A minimal footprint and transparent, user-friendly design means the SpeedStile FL can be placed in any environment where space is limited and aesthetics are valued. With its sophisticated sensor system and unobtrusive, contactless security barriers, the SpeedStile FL is able to accommodate a high throughput while effectively preventing unauthorized access.

The SpeedStile FL features an extensive range of customization options to suit any architectural and design need, including a selection of cabinet lengths, top lid materials, and casework finishes. The modular build allows for a variety of layouts, such as a single ADA compliant lane or a combination of standard and ADA compliant lanes.

Gunnebo has equipped some of the most prestigious buildings in the world with entrance security solutions that protect people and assets by regulating and controlling access. The SpeedStile FL, like all of Gunnebo's security solutions, is durable and reliable, thus reducing operational and maintenance costs.

Quiet and smooth in operation, the SpeedStile FL offers unsurpassed throughput while ensuring unauthorized users are kept out of secure spaces. Applications include public and commercial buildings, government buildings, colleges, and universities.

SpeedStile FL

Speed Gate with Swinging Glass Barrier

TECHNICAL SPECIFICATIONS

Orientation	Bi-Directional	
Unit Dimensions	FL 1500	FL 1925
Casework Length	59.1"	75.8"
Casework Height	39.4"	39.4"
Casework Width	6.7"	6.7"
Walkway Width	24.8" (STD) or 39.0" (ADA Compliant)	23.8" (STD) or 35.6" (ADA Compliant)
Glass Height	36.0", 47.2", or 70.9"	36.0", 47.2", or 70.9"
Drive	Motorized	
Materials	Pedestal	304 grade stainless steel and 0.53" thick tempered glass inlay
	Pedestal Lid	Anodized aluminum black or silver (other options available)
	Barrier	0.39" thick tempered glass or optional clear acrylic
Drive Mechanism	The moving panels are directly mounted to the output shaft of a DC electric motor and gearbox. The motor and gearbox assembly is mounted vertically in the central column. The moving panel position is monitored by a rotary encoder and the location, speed, and movement are controlled by microprocessor control system. The opening and closing speeds, home, and end positions are adjustable within the controller. Safety photocells prevent the panels from closing on an obstruction. Should the normal panel operation encounter an obstruction, the controlling logic detects an abnormal condition and stops the panels from moving.	
Function	Passage in both directions electronically controlled. Default mode is Normally Closed (NC), and lane will open only upon acceptance of an authorized signal.	
Tailgate Detection	Provided through strategically located infrared sensors to accurately monitor pedestrian movement.	
Operation	On receiving a signal from the access control system or pushbutton, the panels open. If an unauthorized person tries to tailgate or enter from the opposite direction, the system detects the unauthorized passage and activates the built-in alarm system.	
Fire Alarm	Input facility, for voltage-free contact supplied by others to effect fail state.	
Power Supply	115VAC 60HZ (230VAC 50HZ available)	
Power Rating	Stand By	20VA
	In Operation	120VA
Logic Voltage	24VAC	
Battery Backup	On power failure, the battery backup will allow the panels to open (or close), stop, and become inactive. The panels will remain in this position until power is restored.	
Flow Rates	30 single users per minute, 40 multiple users per minute (approximate figures).	

SpeedStile FL

Speed Gate with Swinging Glass Barrier

OPERATIONAL MODES & NOTIFICATIONS

Interface

Potential free contact provided by either card reader or pushbutton input. Card reader *inhibit* and *reset* signals are available as standard. The unit has an adjustable time out facility if required; the *go ahead* symbol will be cancelled if the passage through the SpeedStile is not completed within a pre-set and field programmable time frame.

Operational Modes

Full Time Barrier (Normally Closed) Mode

The swinging panels remain closed until a valid access control card is presented. Tailgaters and unauthorized entries are signaled by an alarm-type tone. If an unauthorized card is presented, the lane will sound an alarm and the panels will remain closed to prevent the user from proceeding further without intervention.

Standard Operating Modes

Switchable via optional pushbutton Desk Top Controller (DTC) or an optional digital touchscreen (HMI):

- Enter/Card In
- Exit/Card Out
- Free Exit/Card Out
- Close
- Reset

Pictogram Lights

LED display pictograms are fitted into the SpeedStile drive columns, one in each direction, to visually assist the user when passing through the unit. *Included as standard.*



Green Arrow

Normal Use

The green arrow symbol is continuously illuminated indicating passage is available. Upon authorization, the green arrow will remain illuminated in the direction of passage authorization, while in the opposite direction a red cross symbol will illuminate to indicate the unit is not available for use or is already in use.



Red Cross

Alarm Conditions

The flashing green arrow indicated free passage to evacuate through the gate. A flashing red cross indicates a fraudulent condition or technical alarm, and passage through the unit is not authorized.

SpeedStile FL

Speed Gate with Swinging Glass Barrier

1500MM UNIT: LAYOUT CONFIGURATION & STANDARD DIMENSIONS

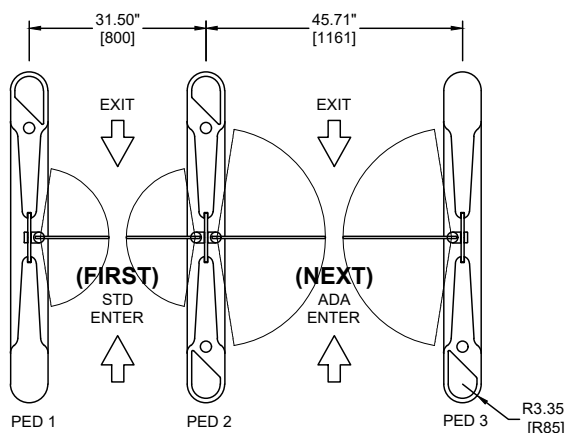

PLAN VIEW

2L3P SPEEDSTILE FL 1500 CARD IN / CARD OUT

Shown with 36.0" high glass barriers. 47.2" and 70.9" high barriers also available.

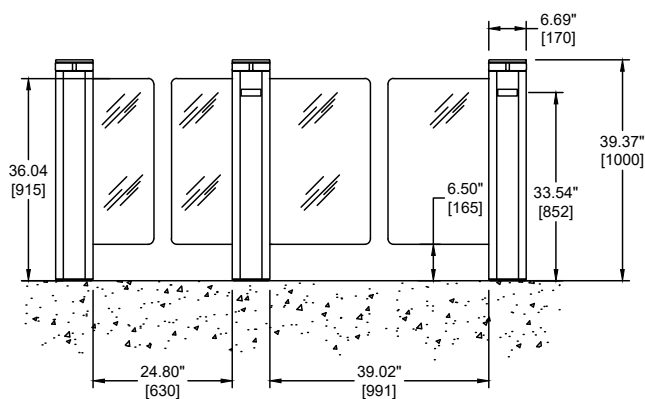

ELEVATION VIEW

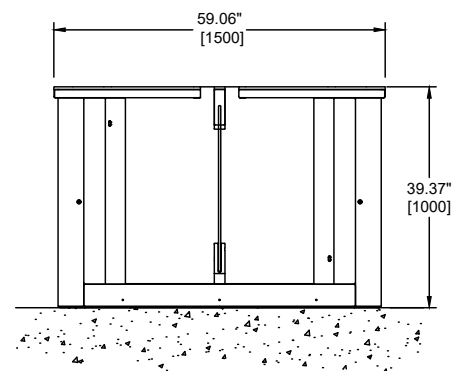

SIDE VIEW

SpeedStile FL

Speed Gate with Swinging Glass Barrier

1925MM UNIT: LAYOUT CONFIGURATION & STANDARD DIMENSIONS

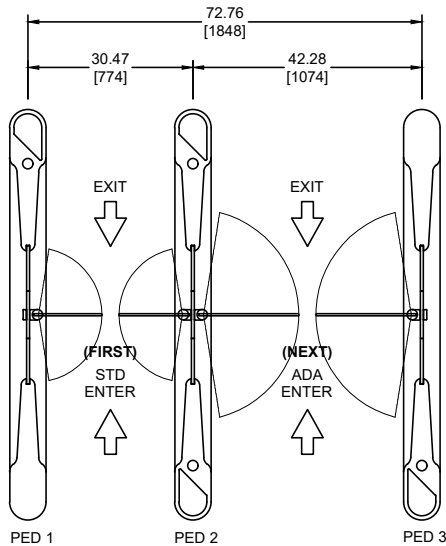

PLAN VIEW

2L3P SPEEDSTILE FL 1925 CARD IN / CARD OUT

Shown with 70.9" high glass barriers. 36.0" and 47.2" high barriers also available.

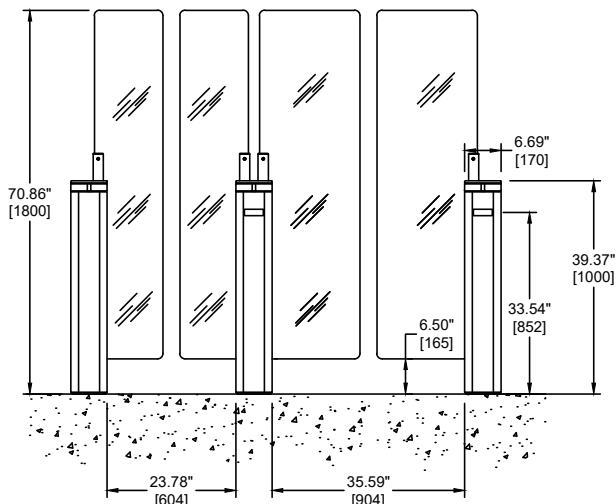

ELEVATION VIEW

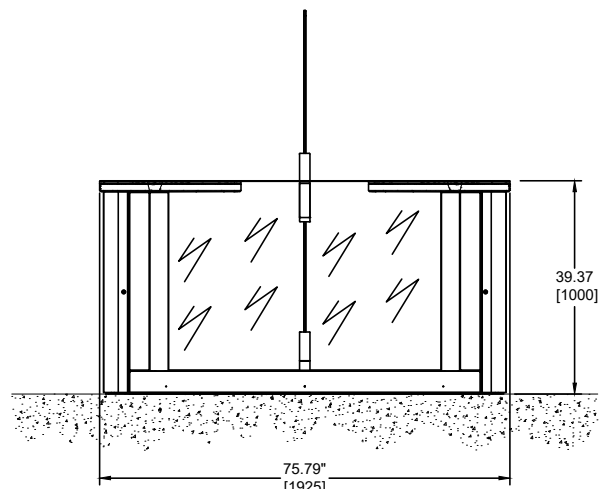

SIDE VIEW

SpeedStile FL

Speed Gate with Swinging Glass Barrier

ACCESSORIES & DESIGN OPTIONS

Alternative Materials, Finishes, and Custom Design	<ul style="list-style-type: none"> • Refer to Gunnebo Entrance Control Inc. for specific material design requirements • Alternative PUR RAL colors, finishes, and effects • Lid material options
Card Reader Options	<ul style="list-style-type: none"> • Integration of customer supplied readers into the SpeedStile top or front inlays • Proximity, magnetic stripe, biometric or barcode readers all compatible • Barcode scanners mounted to accommodate visitor access
Remote Lane Control	<ul style="list-style-type: none"> • Simple pushbutton console to control the SpeedStile barrier release • Custom remote pushbutton console to specific requirements • Casework mounted pushbutton • Digital touchscreen with advanced controls
Alternative Mounting	Specialized mounting base platforms giving concealed cableway and requiring no drilling, trenching, or core drilling to the floor.
Counting	LCD and electromechanical counter
Lane Lights and Logos	<ul style="list-style-type: none"> • Mounted in the SpeedStile drive column to act as traffic light flow control • Custom LED lane lighting • Custom logos and etching on SpeedStile barrier
Infill Panels	Where extra space presents in a design, integrated or standalone space infill solutions can be provided.
Elevator Destination Dispatch	Mounting integration of customer supplied LCD screens for elevator destination dispatch systems.

For further information, please contact:

Gunnebo Entrance Control Inc.
 535 Getty Ct., Benicia, CA 94510
 Tel: 513-666-4821
 Email: info@gunnebo.us
www.gunneboentrancesecurity.com

Gunnebo Entrance Control, Inc. is a company within the Gunnebo Group:
 Gunnebo AB | Box 5181 SE-402 26 Goteborg, Sweden | Tel: +46 31 83 68 00 | www.gunnebo.com

Note: In pursuit of its policy of continuous refinement and improvement, Gunnebo Entrance Control reserves the right to modify design and details at any time and without notice.